



# L17: Motors and Position Determination





# Controlling Position



- **Feedback is used to control position.**
  - Measure the position, subtract a function of it from the desired position and then use this resulting signal to drive the system towards the desired position. This is negative feedback.
  - The natural frequencies of the feedback system are the “zeros” of  $1 + G(s)H(s)$ .
    - The total system is unstable if these “zeros” are in the right half plane (RHP). With 180 degrees phase shift, “negative” feedback becomes “positive” feedback.
    - So we want these “zeros” to be in the left half plane (LHP).
    - Putting an integrator into  $H(s)$  drives steady state error to zero.
    - But high order systems are more likely to have RHP zeros.
    - Time delay and high gain lead to RHP zeros.

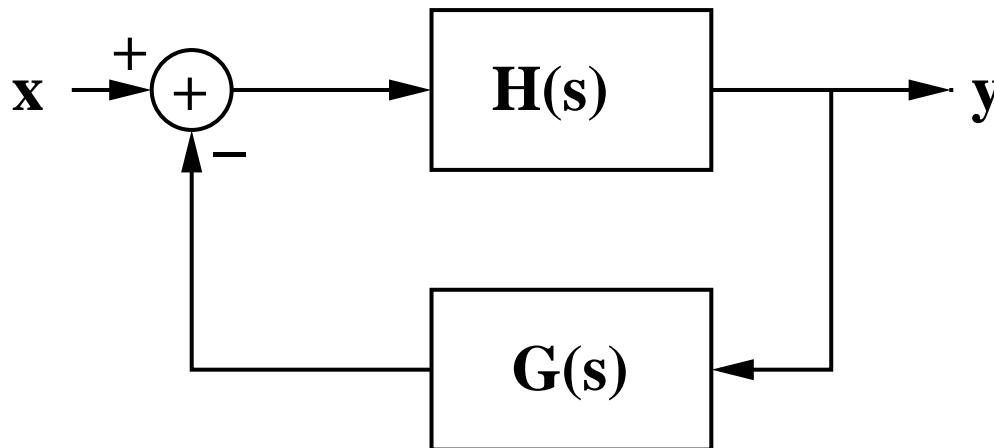

$$\frac{Y(s)}{X(s)} = \frac{H(s)}{1 + G(s)H(s)}$$



# Servos



- We can control parts of the servo, but the system dynamics is often a part we cannot control.
  - The system dynamics results from masses, springs, losses, etc.
- Likely, we will implement servos as digital systems.
  - Digital systems are more flexible to design.
    - They are more repeatable; they are not subject to gain drift.
    - We can use as many bits as we like so we can keep the computation noise small.
  - Digital systems can have significant delays.
    - These delays are sometimes fixed, but are sometimes stochastic.

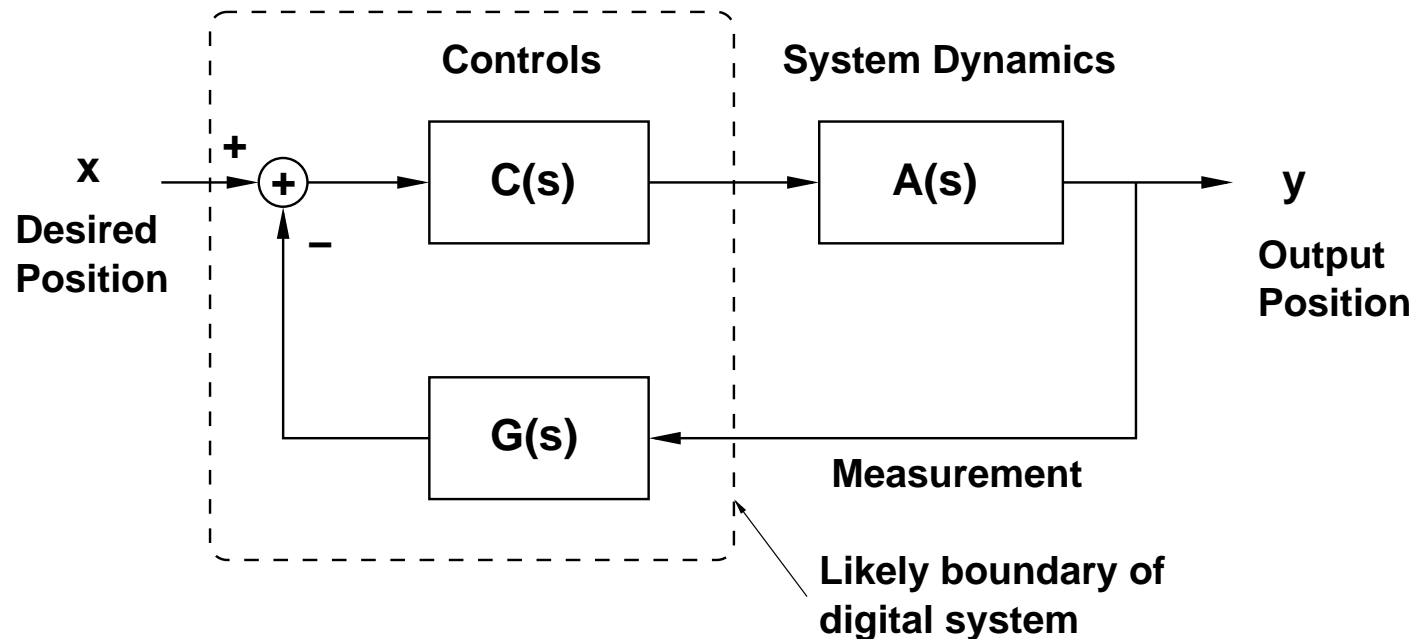



# Analog Position Measurements



Voltage is proportional to position.

A linear or rotary potentiometer can be used.

Accuracy is limited to that of the potentiometer and the noise of the power supply voltage.

Two sinusoidal potentiometers are used.

$$V_1 = V_0 \cos(\theta)$$

$$V_2 = V_0 \sin(\theta)$$

This can also be done magnetically.

This is called a resolver and requires a complex analog signal detection. The computation can be done with either analog or digital circuitry.

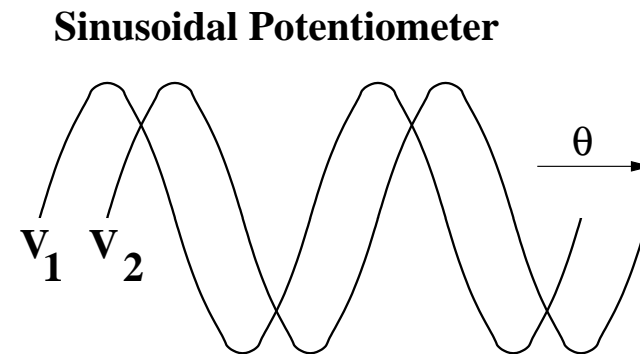
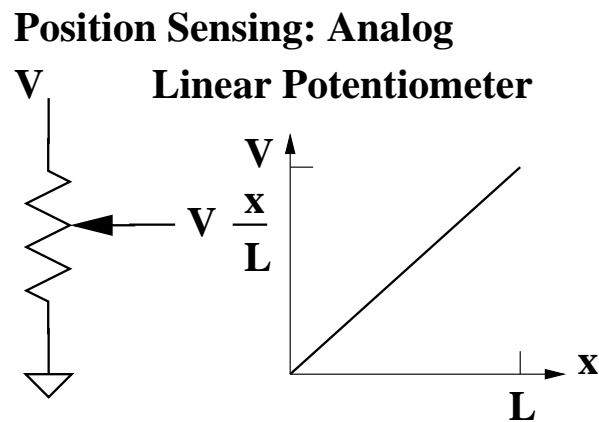



# Digital Position Measurement



- Sense light transmission to determine position.
  - Typically through a transparent sector
  - Gives a reading over a range of positions.
    - Depends on extent of transparent sector.
  - One may need a lot of sensors to determine multiple positions.

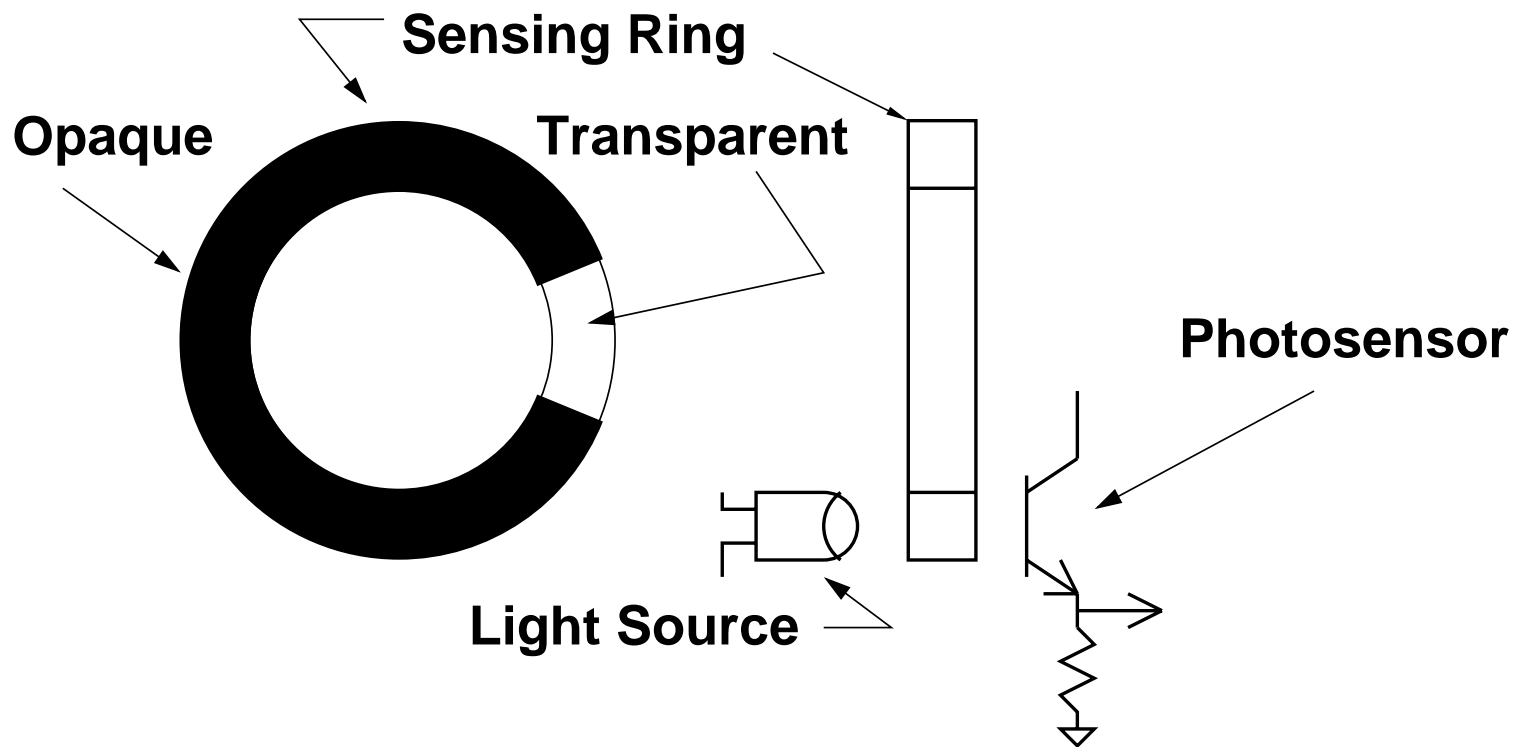



# Digital Absolute Position



- Typically, this is used for relatively low resolutions.

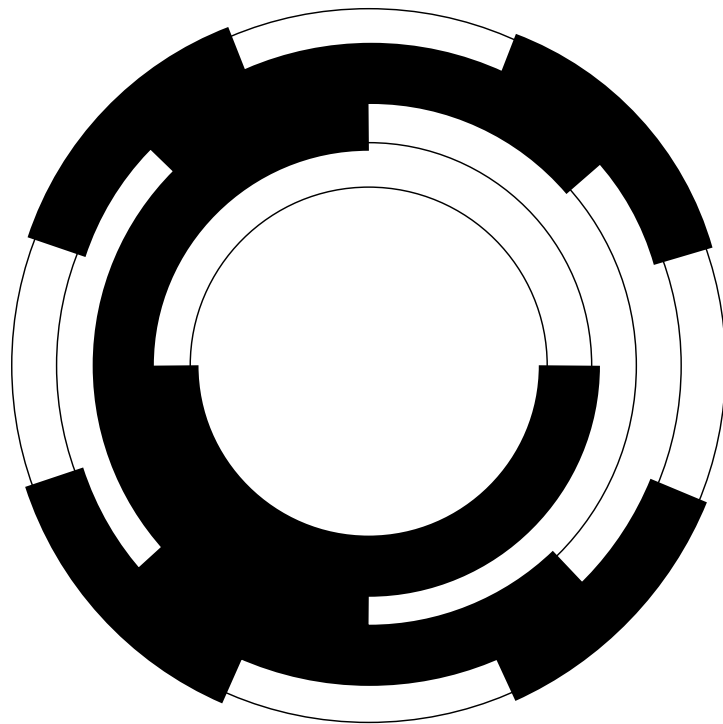

Here is a 4-bit (22.5 degree) resolution wheel.

One source per sensor bit

Can make these wider.  
Resolution is

$$\frac{360^{\circ}}{2^N}$$

Use a Gray Code to eliminate chatter.

0	0	0	0
0	0	0	1
0	0	1	1
0	0	1	0
0	1	1	0
0	1	1	1
0	1	0	1
0	1	0	0
1	1	0	0
1	1	0	1
1	1	1	1
1	1	1	0
1	0	1	0
1	0	1	1
1	0	0	1
1	0	0	0



# Two Phase Encoder



- Two Source – Sensor Sets
  - Their position is offset by half the sector width.
  - This example has 30 degree sectors
  - and 15 degree resolution.

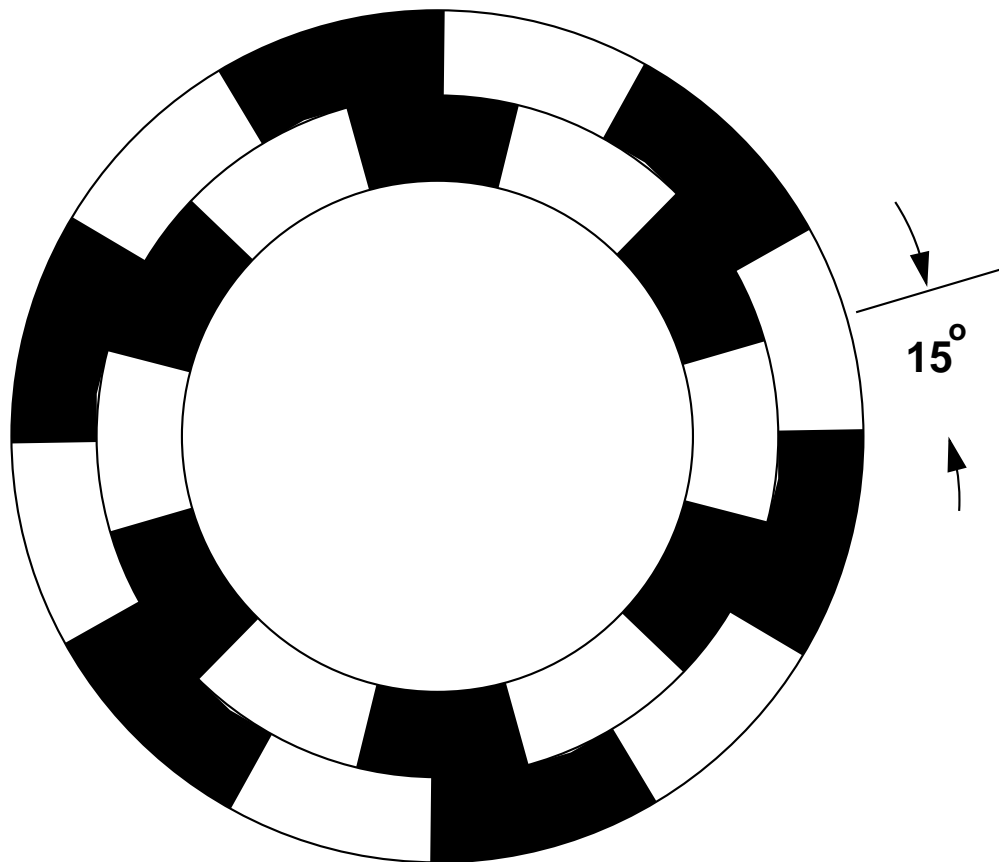



# Use of Two Phase Encoder



- This circuit generates:
  - An Up/Down signal depending on whether the motion is clockwise (CW) or counterclockwise (CCW).
  - A clk signal which rising edge is to operate the counter.

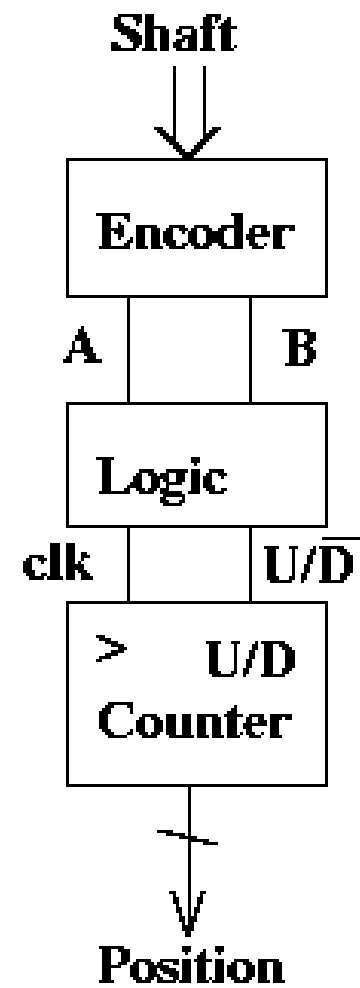
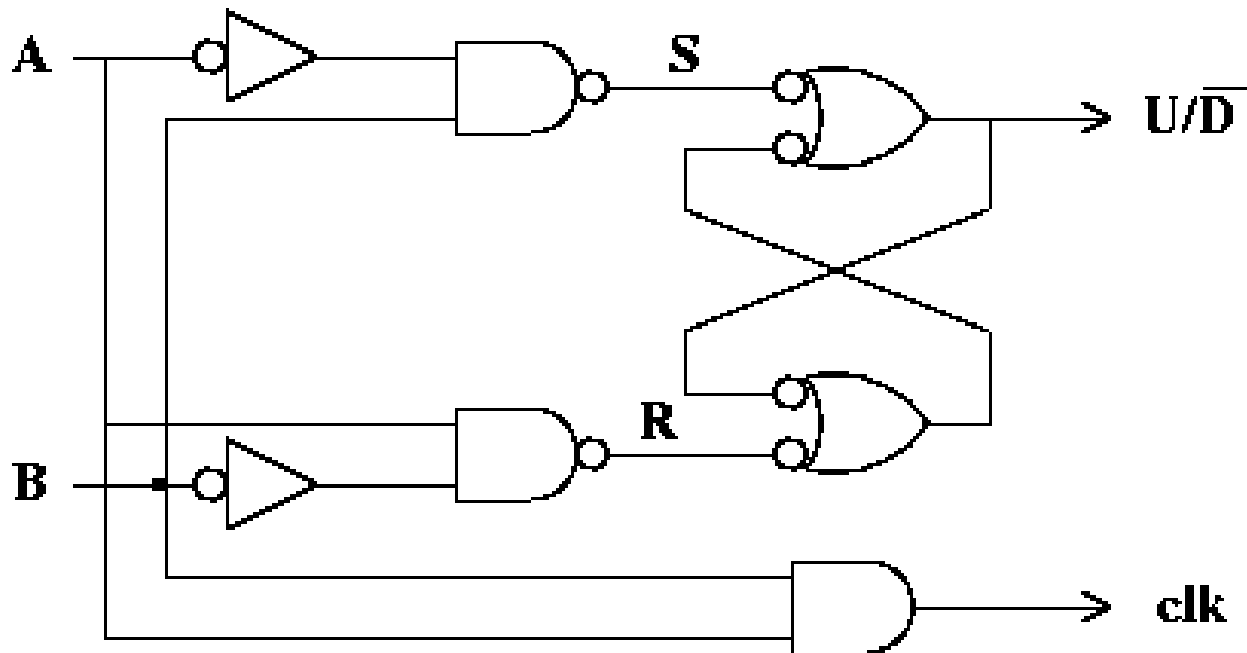



# Waveforms



- A and B are signals derived from sensors.
- Rotating one way, the rising edge of clk is when U/D is high.
- Rotating the other way, the rising edge of clk is when U/D is low.

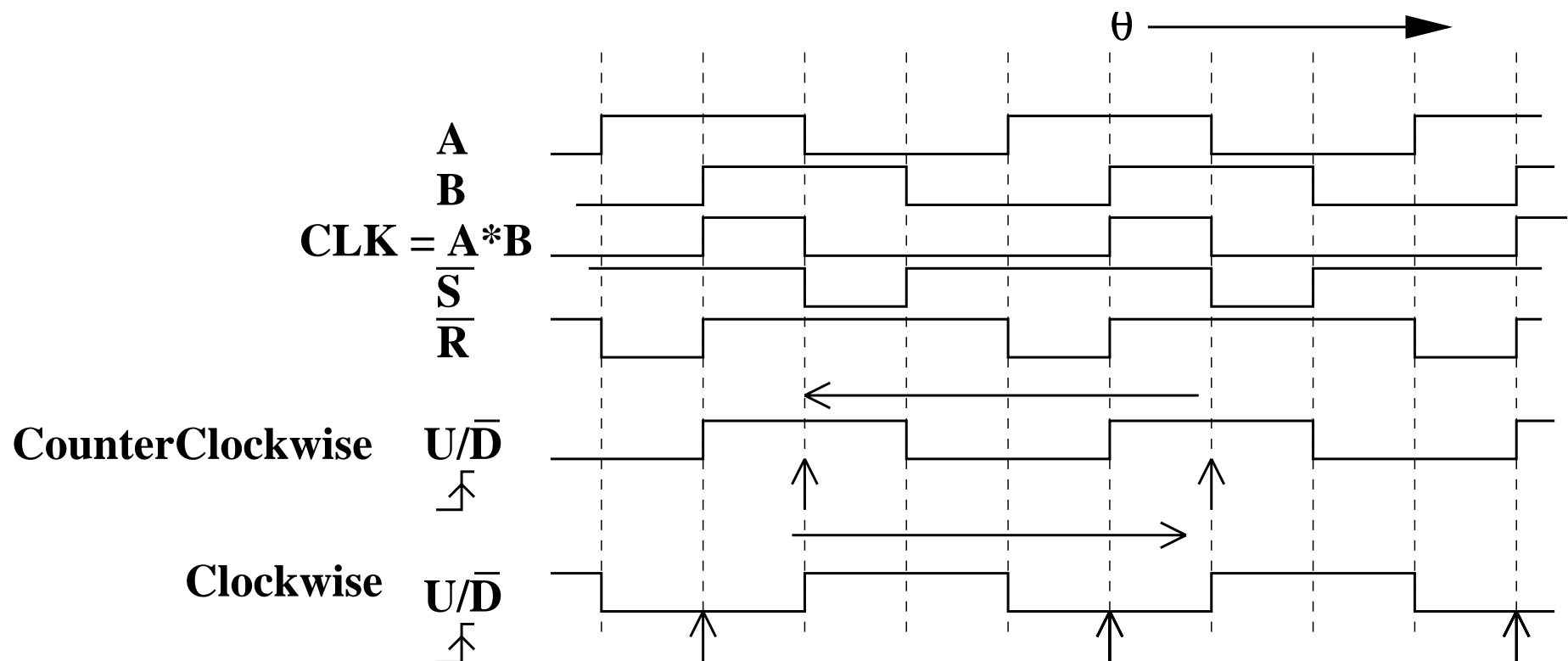



# Another Way of Making an Encoder



- Use two sensors like the two phase encoder but use only one ring and displace the sensors by  $\frac{1}{2}$  band.
- Add another ring and a sensor to sense the “home” position.

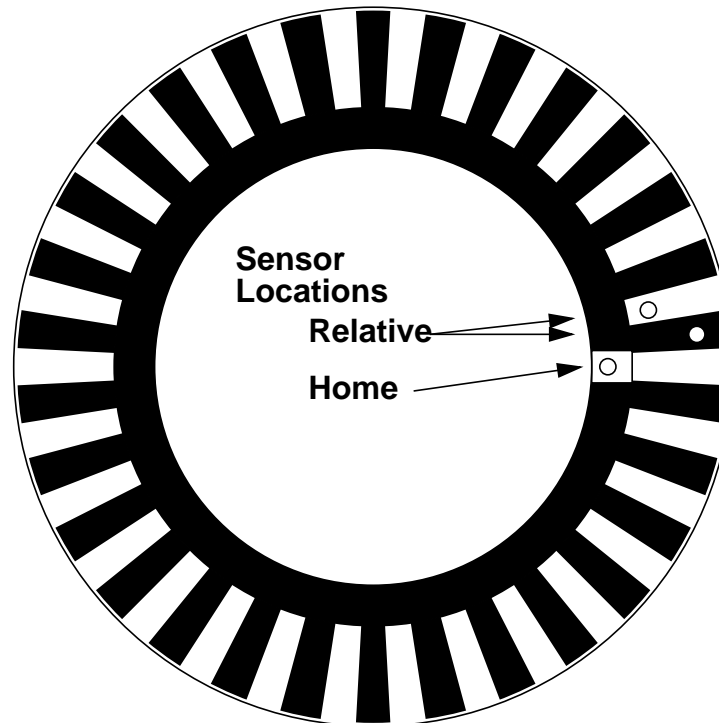



# Motors



- Simple servomechanisms are made with DC motors.
  - DC motor model is very simple:
    - It consists of a resistor in series with a voltage source.
    - The voltage source is proportional to the rotational speed.
  - The mechanical system (controlled system) determines the speed as influenced by the torque.

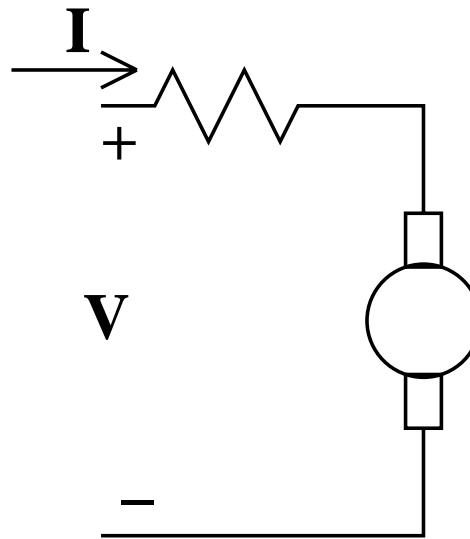

$$V = G \Omega + R I$$

$$\text{Torque } T = G I$$



# Permanent Magnet DC Motors



- They are very commonly used.
  - The 'Back Voltage' is proportional to speed.
  - The torque is proportional to the current.
- Servo strategy:
  - Command torque by setting current.
  - Measure the speed.
- Running open loop:
  - There is a 'zero torque' speed.
  - Torque is proportional to the difference from that speed.

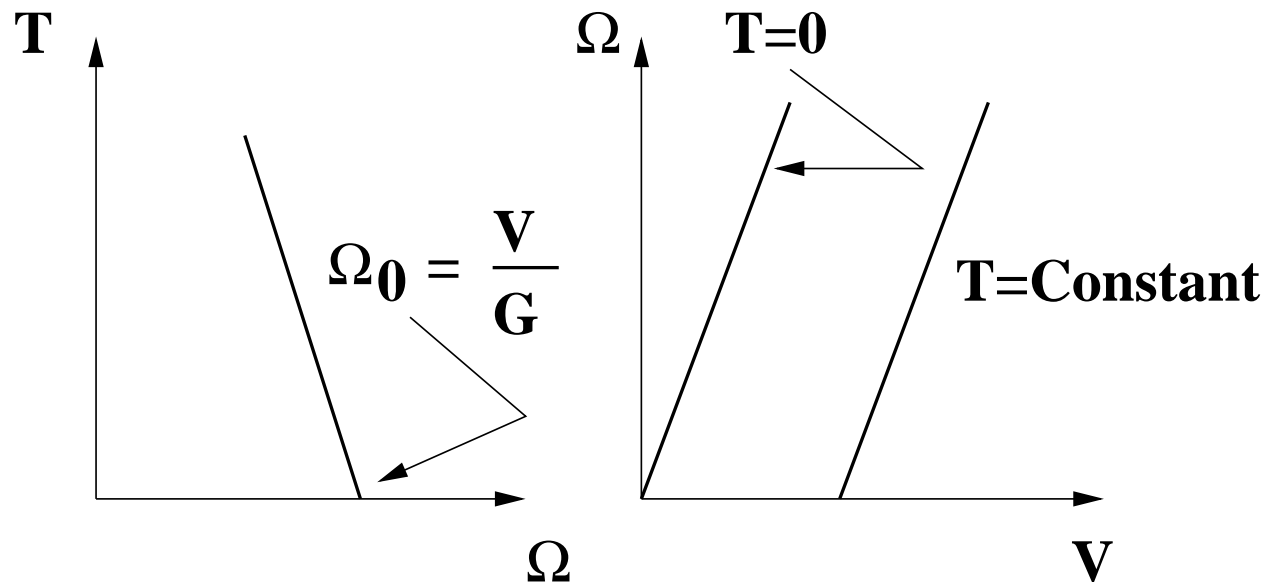



# Stepper Motors



## ■ Digital Motors

- Two 'stacks' (phases)
- Usually biased by permanent magnets
- Move a discrete distance per 'step'.
- This is an axial view cut through both of two sections.

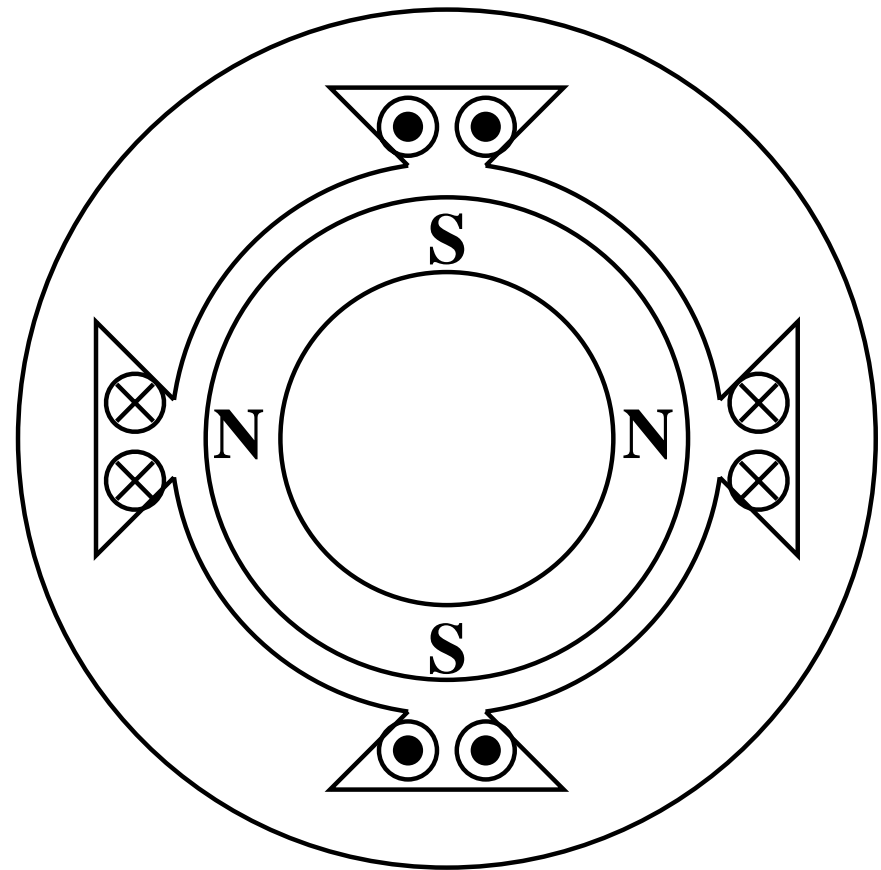
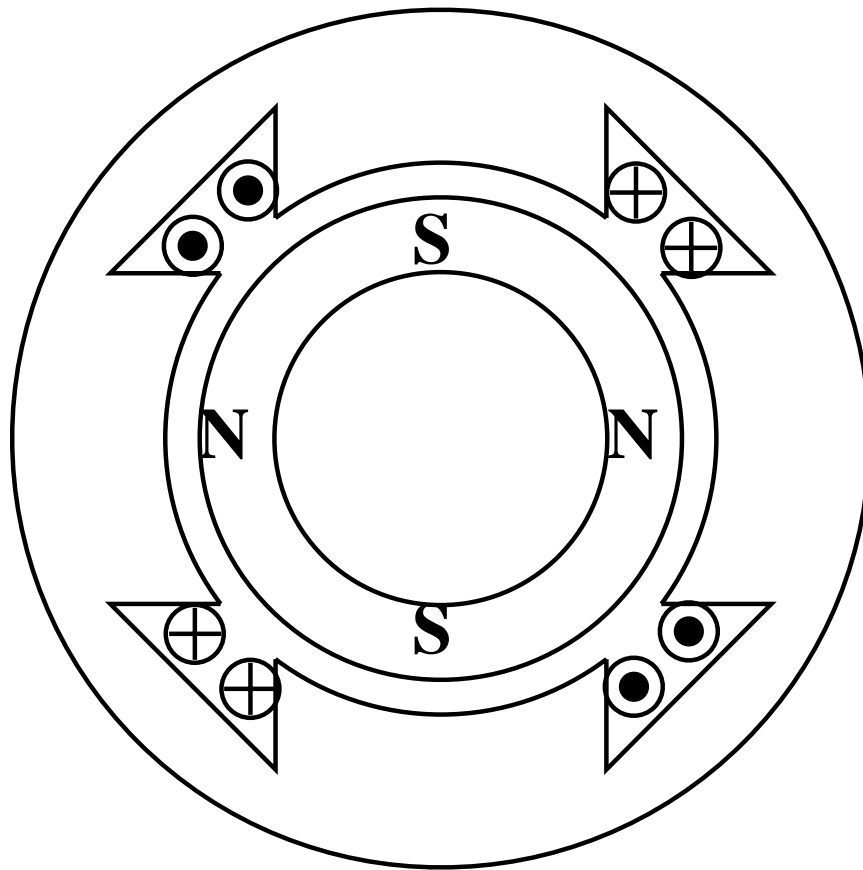

# Stepper Motor Windings



- Two distinct 'phases'
  - May be driven as distinct windings.
  - Or may be driven as 'bifilar' windings.
  - Bifilar is easier but less efficient.

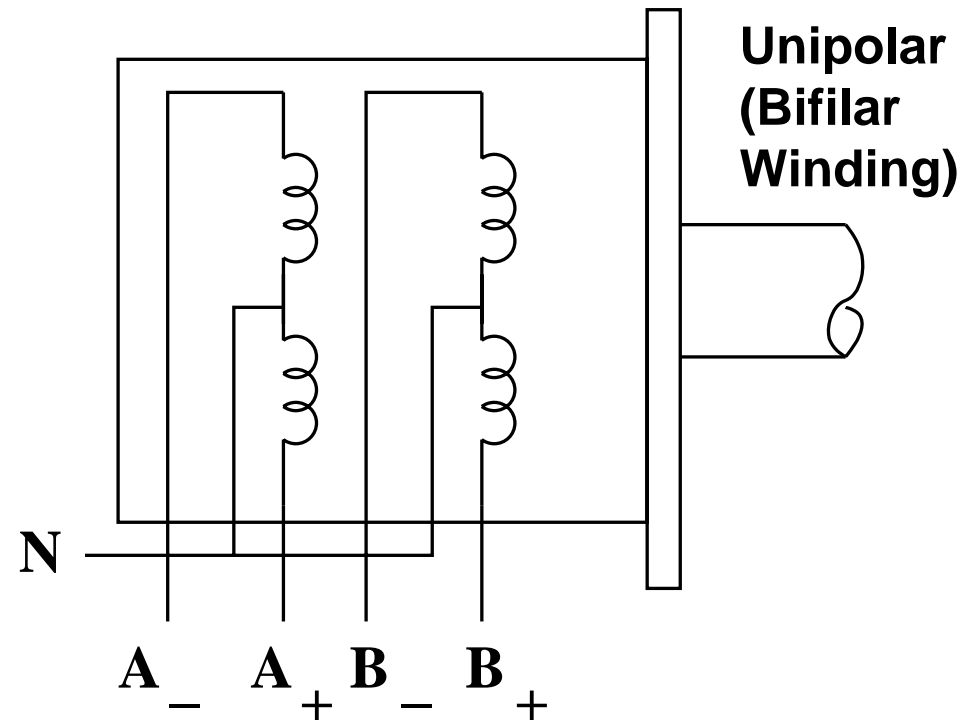
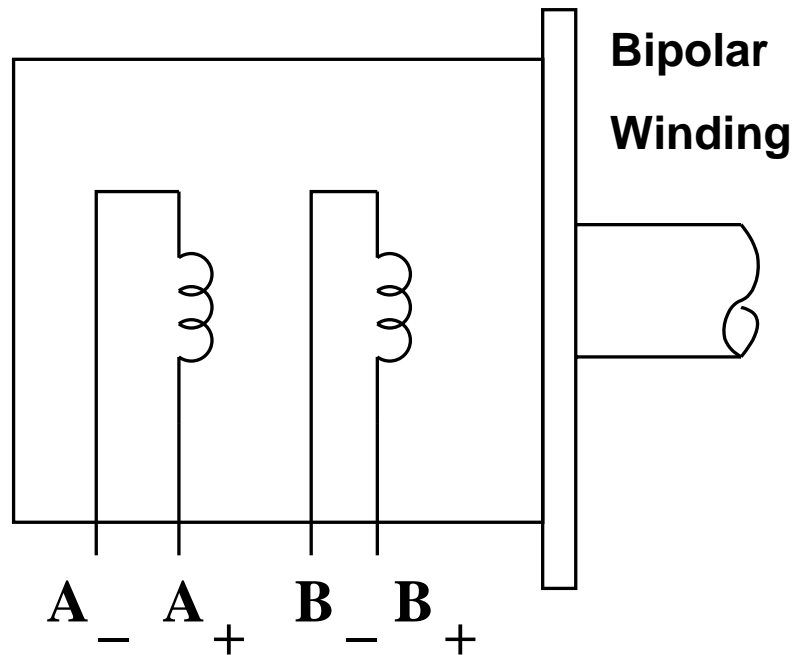



# Bipolar Winding



- Driven by 'H bridges' of transistors
  - Can put current through windings in either direction.
  - But note that the upper transistor drive is tricky.
  - Uses all of the winding.

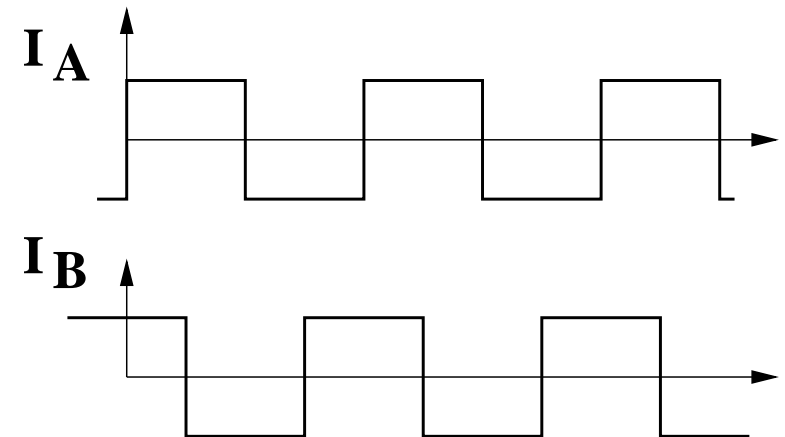
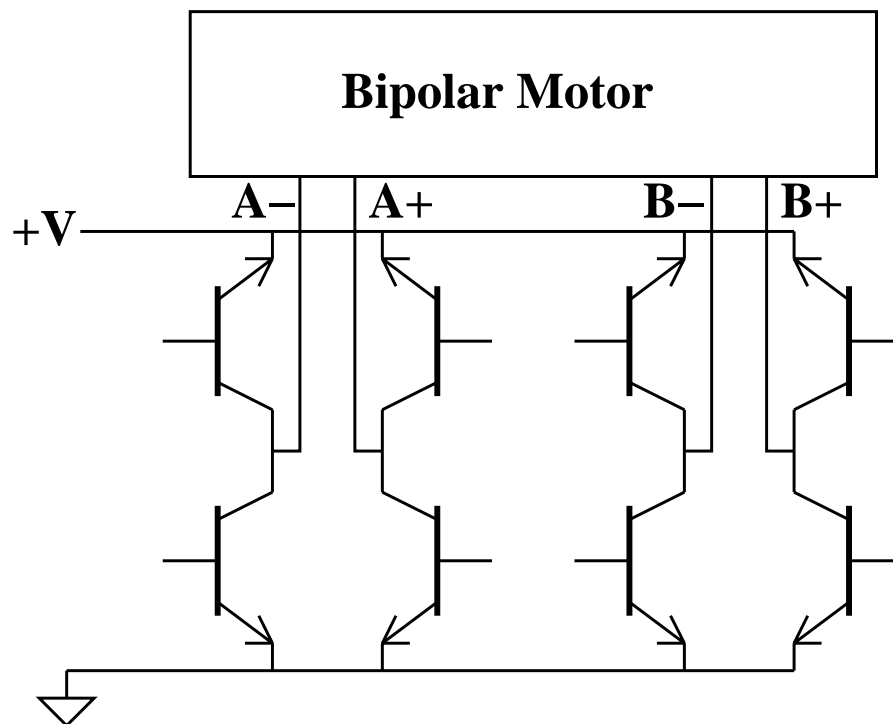



# Bifilar Winding



- Driven by four transistors to ground.
  - Note that the center of the windings is held high.
  - Transistors are between winding and ground.
  - NPN bipolar transistors work well.
  - Transistor drives are easily handled.

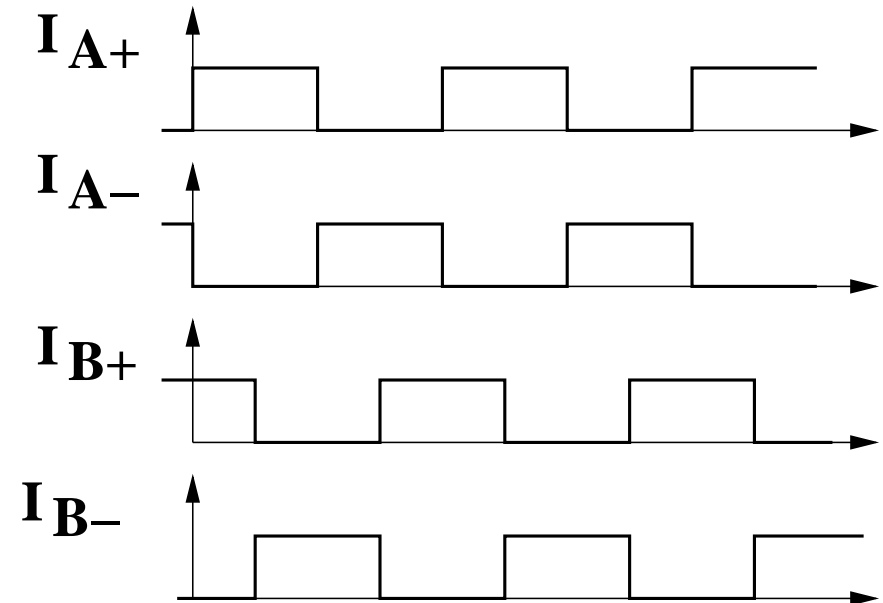
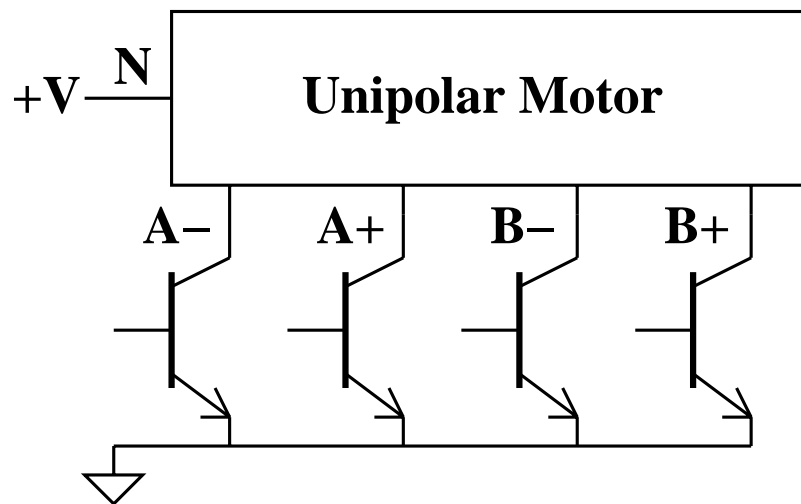



# Motors Run in Either Direction



## ■ Current drive strategy:

### Bipolar Winding

Step	$I_A$	$I_B$
1	+	+
2	+	-
3	-	-
4	-	+

Clockwise  
 ↓
 

 ↑  
 Counter-Clockwise

### Bifilar Winding

Step	$I_{A+}$	$I_{A-}$	$I_{B+}$	$I_{B-}$
1	1	0	1	0
2	1	0	0	1
3	0	1	0	1
4	0	1	1	0

Clockwise  
 ↓
 

 ↑  
 Counter-Clockwise



# Dynamics are Important



- Stepper can hold a certain torque.
- Stepper can carry more torque at low speed.
- At high speed, torque must be de rated.
- Motors draw **CURRENT!** Make sure your power supply is adequate by measuring the power supply voltage with a 'scope.
  - Use an external supply, not the kit supply.
    - You do not want motor drive noise in your digital circuit (or analog circuit).
- You need to make sure that devices can handle the current and torque.

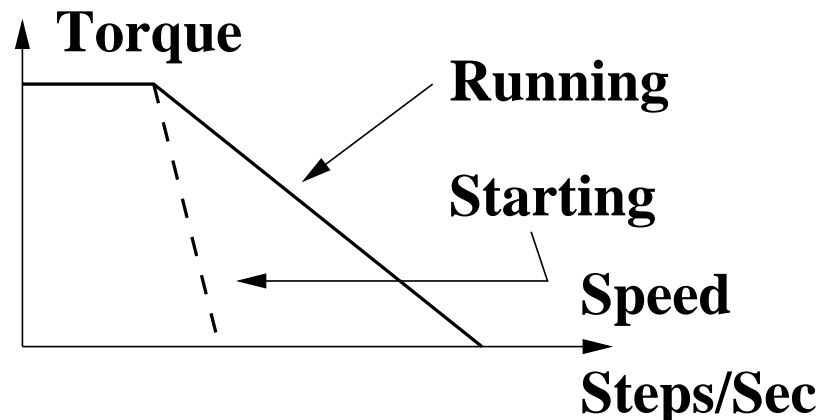

**Must sometimes 'ramp up' speed.  
Holding torque is limited by  
heating and by saturation.**